



GPS & GLONASS Antenna Module
MR31513PGMGG

Revision History

Date	Reversion	Description
2022/1/12	1.0	First Draft, Based on MR31513PGMGG

Directory

1. Product Information	4
1.1 Product Description	4
1.2 Product Features	4
1.3 Product Specifications	5
1.4 DC Electrical Characteristics	6
2. Technical Information	7
2.1 Module Pin Assignment	7
2.2 Dimensions	7
3. Application Circuit : (Example)	8
4. Software Interface	9
5. Protocol	10
5.1 GGA – Global Positioning System Fix Data	10
5.2 GLL – Latitude/Longitude	11
5.3 GSA – GPS & GLONASS DOP and Active Satellites	12
5.4 GSV – GPS & GLONASS Satellites in View	13
5.5 RMC – Recommended Minimum Specific GNSS Data	14
5.6 VTG – Course Over Ground and Ground Speed	15

1. Product Information

1.1 Product Description

MR31513PGMGG-C is a complete standalone GPS/GLONASS antenna module. The module is powered by GOKE chip, which provides superior sensitivity and performance even in urban canyon and dense foliage environment. The miniature size makes the module easy to integrate into portable device like PDAs, camera and vehicle locators.

Applications

- Wearable and portable devices
- Automotive Navigation
- Personal Positioning
- Fleet Management
- Mobile Phone Navigation
- Marine Navigation

1.2 Product Features

- Small size with antenna module
- Fast TTFF at low signal level
- Build on high performance, GOKE chip set
- Low power consumption: Max 45mA@3.3V
- Built-in high gain LNA
- NMEA-0183 compliant protocol
- Patch Antenna Size: 12x12x4mm
- Communication type: UART/TTL
- RoHS Compliant

1.3 Product Specifications

GPS Receiver		
Chip	GOKE	
Frequency	Code 66 search channels, 22 synchronous tracking channels GPS&, QZSS, GALILEO: L1 1575.42MHz C/A GLONASS: L1OF 1602MHz BeiDou: B1 1561.098MHz SBAS: WAAS, EGNOS, MSAS, GAGAN	
Update Rate	1Hz (default) , up to 10Hz	
Position Accuracy	Position	Dynamic: < 10m CEP @-130 dBm Static state: < 5m CEP @-130 dBm
	Accuracy of 1PPS Signal	Typical accuracy: ±40ns / Time pulse width 100ms
	Acceleration Accuracy	Without aid: 0.1m/s ²
Startup Time	Cold start	35s typ @-130dBm
	Warm start	30s typ @-130dBm
	Hot start	1s typ @-130dBm
Sensitivity	Acquisition	-147dBm
	Re-acquisition	-156dBm
	Tracking	-165dBm
GNSS Operating limit	Altitude	18,000m
	Velocity	515m/s
	Acceleration	4G
Protocol Support	UART Port: TXD and RXD 9600bps (default), Baud rate supports 4800bps to 460800bps NMEA 0183 Protocol	
Environment	Operation temperature	-40°C ~ +85°C
	Storage temperature	-45°C ~ +125°C
Physical Characteristics	Size	15.2±0.30 ×13±0.20 ×6.43±0.20mm(H)
	Weight	Approx. 3.9g

1.4 DC Electrical Characteristics

Parameter	Min.	Typ.	Max.	Units
Input Voltage	2.8	3.3	4.3	Volt
Acquisition		30		mA
Tracking		28		mA
Backup Battery		20		uA
Low Level Output Voltage (VOL)			0.4	Volt
High Level Output Voltage (VOH)	2.4			Volt
Low Level Input Voltage (VIL)			0.8	Volt
High Level Input Voltage (VIH)	2			Volt
Low Level Output Current (IOL)		2		mA
High Level Output Current (IOH)		2		mA

2. Technical Information

2.1 Module Pin Assignment



Pin No.	Pin Name	I/O	Remark
1.	VBAT	I	RTC Battery Input
2.	TXD	O	UART/TTL Serial Data Output ,Pull up (75KΩ) if not used
3.	RXD	I	UART/TTL Serial Data Input, Pull up (75KΩ) if not used.
4.	VCC	I	Module Power Supply
5.	GND	G	Ground
6.	PPS	O	Time Pulse(1PPS)
7.	GPIO1	I/O	General purpose I/O

2.2 Dimensions

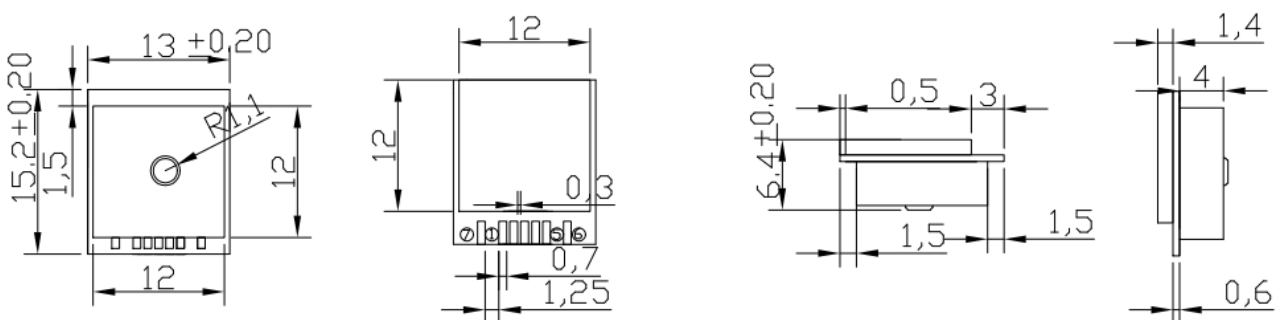

Front view

Rear view

Profile view

3. Application Circuit : (Example)

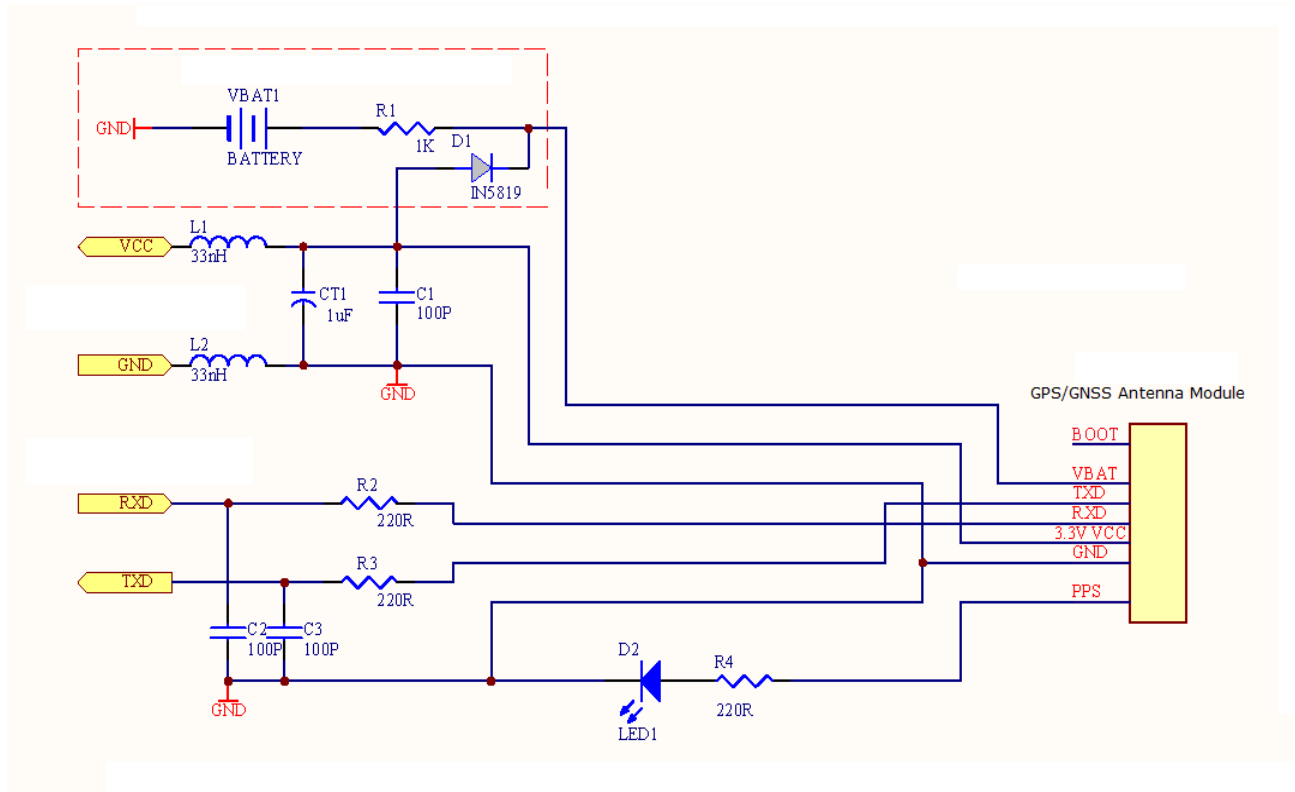

4. Software Interface

Table 4.1 NMEA output message

NMEA	Description
GGA	Global positioning system fixed data
GLL	Geographic position - latitude/longitude
GSA	GNSS DOP and active satellites
GSV	GNSS satellites in view
RMC	Recommended minimum specific GNSS data
VTG	Course over ground and ground speed

5. Protocol

5.1 GGA – Global Positioning System Fix Data

For example:

\$xxGGA, 161229.487,3723.2475,N, 12158.3416,W, 1,07,1.0,9.0,M.0000*18

Field	Name	Example	Units	Description
1	Message ID	\$xxGGA		GGA protocol header
2	UTC Position	161229.487		hhmmss.sss
3	Latitude	3723.2457		ddmm.mmmm
4	N/S indicator	N		N=north or S=south
5	Longitude	12158.3416		dddmm.mmmm
6	E/W Indicator	W		E=east or W=west
7	Position Fix Indicator	1		See Table 5.1-1
8	Satellites Used	07		Range 0 to 12
9	HDOP	1.0		Horizontal Dilution of Precision
10	MSL Altitude	9.0	meters	
11	Units	M	meters	
12	Geoids Separation		meters	
13	Units	M	meters	
14	Age of Diff.Corr.		second	Null fields when DGPS is not Used
15	Diff.Ref.Station ID	0000		
16	Check sum	*18		
18	<CR> <LF>			End of message termination

Table 5.1-1 Position Fix Indicators

Value	Description
0	Fix not available or invalid
1	GPS & Glonass SPS Mode, fix valid
2	Differential GPS & Glonass, SPS Mode, fix valid
3	GPS & Glonass PPS Mode, fix valid

5.2 GLL – Latitude/Longitude

For example:

\$xxGLL , 3723.2475, N,12158.3416, W,161229.487, A*2C

Field	Name	Example	Units	Description
1	Message ID	\$xxGLL		GLL protocol header
2	Latitude	3723.2475		ddmm.mmmm
3	N/S Indicator	N		N=north or S=south
4	Longitude	12158.3416		dddmm.mmmm
5	E/W Indicator	W		E=east or W=west
6	UTC Position	161229.487		hhmmss.sss
7	Status	A		A=data valid or V=data not valid
8	Check sum	*2C		
9	<CR> <LF>			End of message termination

5.3 GSA – GPS & GLONASS DOP and Active Satellites

For example:

\$xxGSA , A, 3, 07, 02, 26,27, 09, 04,15, , , , , , 1.8,1.0,1.5*33

Field	Name	Example	Units	Description
1	Message	\$xxGSA		GSA protocol header
2	Mode 1	A		See Table 5.3-1
3	Mode 2	3		See Table 5.3-2
4	Satellite Used	07		Sv on Channel 1
5	Satellite Used	02		Sv on Channel 2
6
7	Satellite Used			Sv on Channel 66
8	PDOP	1.8		Position Dilution of Precision
9	HDOP	1.0		Horizontal Dilution of Precision
10	VDOP	1.5		Vertical Dilution of Precision
11	Check sum	*33		
12	<CR> <LF>			End of message termination

Table 5.3-1 Mode 1

Value	Description
1	Fix not available
2	2D
3	3D

Table 5.3-2 Mode2

Value	Description
M	Manual-forced to operate in 2D or 3D mode
A	Automatic-allowed to automatically switch 2D/3D

5.4 GSV – GPS & GLONASS Satellites in View

For example :

\$xxGSV , 2, 1, 07, 07, 79,048, 42, 02, 51,062, 43, 26, 36,256, 42, 27, 27, 138,42*71

\$xxGSV, 2, 2, 07, 09, 23,313, 42, 04, 19, 159, 41, 15,12,041, 42*41.

Field	Name	Example	Units	Description
1	Message ID	\$xxGSV		GSV protocol header
2	Number of Message	2		Range 1 to 3
3	Message Number	1		Range 1 to 3
4	Satellites in View	07		
5	Satellite ID	07		Channel 1(Range 1 to 66)
6	Elevation	79	degrees	Channel 1(Maximum 90)
7	Azinmuth	048	degrees	Channel 1(True, Range 0 to 359)
8	SNR(C/NO)	42	dBHz	Range 0 to 99,null when not tracking
9
10	Satellite ID	27		Channel 4(Range 1 to 66)
11	Elevation	27	degrees	Channel 1(Maximum 90)
12	Azimuth	138	degrees	Channel 1(True, Range 0 to 359)
13	SNR(C/NO)	42	dBHz	Range 0 to 99,null when not tracking
14	Check sum	*71		
15	<CR> <LF>			End of message termination

5.5 RMC – Recommended Minimum Specific GNSS Data

For example:

\$xxRMC, 161229.487, A, 3723.2475, N, 12158.3416, W, 0.13,309.62, 120598,, *10

Field	Name	Example	Units	Description
1	Message ID	\$xxRMC		RMC protocol header
2	UTS Position	161229.487		hhmmss.sss
3	Status	A		A=data valid or V=data not valid
4	Latitude	3723.2475		ddmm.mmmm
5	N/S Indicator	N		N=north or S=south
6	Longitude	12158.3416		dddmm.mmmm
7	E/W Indicator	W		E=east or W=west
8	Speed Over Ground	0.13	Knots	
9	Course Over	309.62	Degrees	True
10	Ground			
11	Date	120598		Dummy
12	Magnetic variation		Degrees	E=east or W=west
13	Check sum	*10		
14	<CR> <LF> End of			End of message termination

5.6 VTG – Course Over Ground and Ground Speed

For example:

\$xxVTG, 309.62, T, M, 0.13, N, 0.2, K*6E

Field	Name	Example	Units	Description
1	Message ID	\$xxVTG		VTG protocol header
2	Course	309.62	Degrees	Measured heading
3	Reference	T		True
4	Course		Degrees	Measured heading
5	Reference	M		Magnetic
6	Speed	0.13	Knots	Measured horizontal speed
7	Units	N		Knots
8	Speed	0.2	Km/hr	Measured horizontal speed
9	Units	K		Kilometer per hour
10	Check sum	*6E		
11	<CR> <LF>			End of message termination